

KMTRONIC
LTD

Relay Controller Model UD4CR User Guide



Contents

- I. CONNECTING AND OPERATION..... 1
 - 1. Security and Handling 1
 - 2. An Overview 1
 - 2.1 Specification 2
 - 2.2 Package Contents..... 2
 - 2.3 Operation Requirements..... 2
 - 3 How to use UPD Four Relay 2
 - 3.1 Connection Details 2
 - 3.2 Installation 4
 - 3.3 List of command set..... 5
 - 4 Additional information 6
 - 4.1 Handle inductive loads 6
 - 5 Technical specifications 7
 - 6 Physical Dimensions 8
 - 7. Other information 9

I. CONNECTING AND OPERATION

1. Security and Handling

Safety Instructions:

This device may connect to LAN port of your computer or router and can be used to control external devices connected to its onboard relays. Incorrect wiring or shorts on the board can potentially cause damage to the controller itself, your computer's LAN controller and/or your computer's motherboard if an external voltage make its way to the LAN interface. Extreme care must be taken when using this device to avoid any damage to your equipment. In particular, make sure you always disconnect the device from the LAN port as well as any other power source when working on the device.

KMTronic, its shareholder, employees, suppliers, distributors and/or resellers are not liable for any damage or loss of data as a result of the use of this device, including special, incidental, or consequential damages resulting from the use of this device, or under any legal theory, including lost profits, downtime, goodwill, damage to or replacement of equipment or property, and any costs or recovering or reproducing any data stored in computers connected to this device.

Your use of this circuit indicates your acceptance of these terms

2. An Overview

KMTronic UDP Four Relay is a versatile product for controlling electrical and electronic devices remotely via web browser. Ease of use and wider operating system compatibility are the primary goals behind the product's design. The simplicity of connection and settings allows user to control and manage relays via web browser. For power users, this module can be controlled by writing programs in various programming languages and controlled via TCP/IP protocol.

Some of possible uses of the module include

- Home Automation
- Lighting Control
- Garden Equipment Control
- Industrial Automation
- Test Fixtures
- DIY and Hobby

And these are some of the languages that can be used for programming

- C/C++/C#
- Visual Basic (VB6, VB2008, VB2010 express and other editions)
- Visual Basic for Applications (Microsoft Office VBA)
- Perl
- Python
- Java
- And many more...

2.1 Specification

- Number of Relays: 4
- Rated voltage: 9 -24V DC
- Relay switching power: 15A/24VDC(125VAC)10A/250VAC
- Communication: LAN Interface
- Dimension : 110mm x 108mm x 25mm (connectors mounted)

2.2 Package Contents

The following is included in the UPD Four Relay package

- UDP Four Relay board

2.3 Operation Requirements

This product is compatible with the following operating systems

- Every OS with available web browser
- Programs over TCP/IP, built with mention above programming languages

3 How to use UDP Four Relay?

3.1 Connection Details

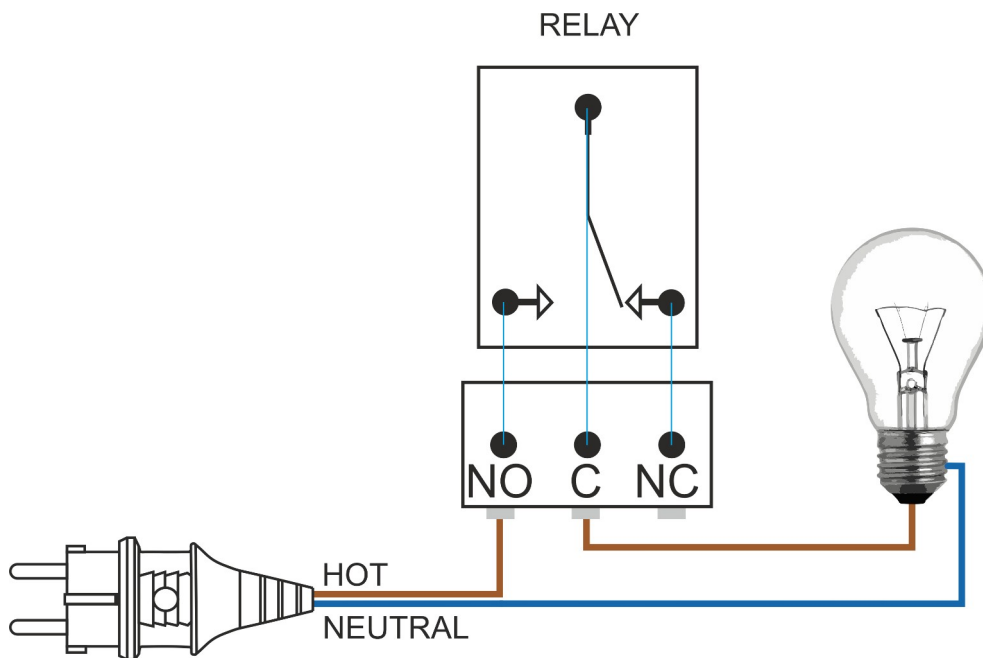

- Above image shows basic connection diagram that can be used in most of the situations. The connection diagram is same for both AC and DC loads. Please make sure to use a freewheeling

diode or snubber circuit if the load is inductive. More details about using inductive loads is available elsewhere in this document. It is important to make sure that the wires used to connect loads are sufficiently rated to handle expected load current. Exercise caution while working with high voltages. Short circuits can cause damage to the module and the PC. The following sections identify individual connections in detail.

IMPORTANT NOTE



This circuit involves high voltage AC main power wiring when used to control high voltage AC devices. Please note that handling, testing and operating high voltage AC powered equipment can be dangerous and fatal when basic safety rules are not followed. ALWAYS disconnect the circuit from the AC line prior to performing any work on the circuit.

If you are inexperienced or not confident in working with high voltage AC powered circuits, we strongly recommend that you DO NOT attempt to use this circuit and seek help of a licensed electrician.

Relay Contacts

All contacts on each relay are available externally on screw terminals for easy user access. The relays are rated for AC and DC supply voltages. Please see the electrical parameter table for more details. Each relay has three contacts (C, NO and NC). C is the common terminal and is used in both normally open and normally closed positions. The contacts NC and C will be connected when the relay is turned off and will be disconnected when relay is turned on. And vice versa, the contacts C and NO will be disconnected when relay is turned off and will be connected when the relay is turned on. Table below summarizes possible relay contact



Relay State	Connection between NC and C	Connection between NO and C
OFF	Close	Open
ON	Open	Close

DC Power Supply

This board need power supply from 9 to 24V DC for function properly. The power supply for the boards is **not optional** and the relay will not switch without this supply. Any off the shelf 9 to 24V DC / 500mA or more power supply can be used for this purpose. Make sure to connect the power supply in correct polarity. Connect the positive terminal of the power supply to the + terminal on the module. Connect negative terminal of the power supply to - terminal of the module.



3.2 Installation

- **Default settings:**

IP address: 192.168.1.199
Subnet Mask: 255.255.255.0
Default Gateway: 192.168.1.1
Username: admin
Password: admin

- **Reset defaults settings:**

Hold Reset button for 10 seconds

- Connect power and LAN cable to router. Open any Internet explorer and type: 192.168.1.199.
If explorer opens new window with request for USER and PASSWORD, enter default Username and Password. That's all and you are ready to control and manage relays. If you cannot open default IP address, follow next:

- Check that IP your router LAN is 192.168.1.1:

<http://kmtronic.com/how-to-find-your-local-ip-address.html>

If LAN IP, your router is different than 192.168.1.1 (192.168.0.1 or 192.168.10.1) you need one time access to network 192.168.1.1 to change default settings.

- Open again the web browser and type: 192.168.1.199.

The following images show the first steps of installing board. By clicking relay buttons you control them – switch on and switch off. In **Configuration** you can change default relay and network settings. **Authorization Configuration** allows to change default Username and Password.

Configuration

Enter the new settings for the board below:

	<input type="checkbox"/> Enable DHCP
IP Address:	<input type="text" value="192.168.1.199"/>
Gateway:	<input type="text" value="192.168.1.1"/>
Subnet Mask:	<input type="text" value="255.255.255.0"/>
HTTP Port:	<input type="text" value="80"/>
UDP Source Port:	<input type="text" value="12345"/>
UDP Destination Port:	<input type="text" value="12345"/>
	<input type="button" value="Save Config"/>

3.3 List of command set

Controlling of the relays is also available with set of ASCII commands which can be send via software program over UDP. The table below contains available commands:

No.	Command	Format	Description
1	FF0101	ASCII	Turn ON relay 1
2	FF0201	ASCII	Turn ON relay 2
3	FF0301	ASCII	Turn ON relay 3
4	FF0401	ASCII	Turn ON relay 4
9	FF0100	ASCII	Turn OFF relay 1
10	FF0200	ASCII	Turn OFF relay 2
11	FF0300	ASCII	Turn OFF relay 3
12	FF0400	ASCII	Turn OFF relay 4
17	FFE0xx	ASCII	<p>xx - HEX representation of relays state MSB - relay4 LSB - relay1</p> <p>Example: xx = 06; //0x06 HEX 0x06 as binary: 00000110</p> <p style="text-align: center;">=></p> <pre> MSB LSB 0 1 1 0 r4 r3 r2 r1 off on on off </pre>
18	FF0000	ASCII	<p>Returns Status of Relays - xxxxxxxx First digit(MSB) is status of Relay1, last(LSB) - status of Relay 4</p> <p>Example: Board returns in ASCII 00000110</p> <pre> MSB LSB 0 1 1 0 r4 r3 r2 r1 off on on off </pre>

4 Additional information

4.1 Handle inductive loads

General-purpose relays are typically designed to drive resistive loads, not inductive loads.

This is why electromechanical life ratings are published for resistive loads and not inductive loads.

Inductive loads can best be defined as anything with a magnetic coil, such as a motor, solenoid, or a transformer. The purpose of this capacitor is to absorb the high voltages generated by inductive loads. Unlike resistive loads, inductive loads love power, and they will do everything they can to hold on to it. The unpleasant result of this power hunger is inductive kickback, and it has a devastating effect on the contact life of most general-purpose relays. This is true of both ac and dc inductive loads, although the inductive kickback is far worse with dc loads due to the constant current characteristic of dc power. How bad is the kickback? A 24-Vdc solenoid with a current consumption as low as a quarter of an amp will create a negative inductive kickback of more than 300 V.

Adding a suppression capacitor could easily reduce the problems. It has to be installed as close as possible to the Relay Board.

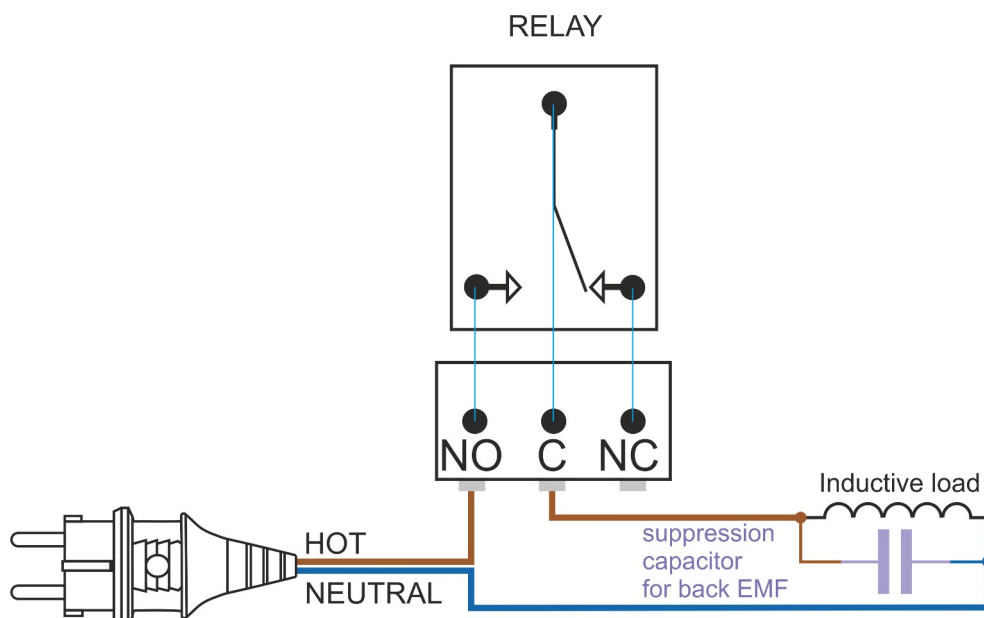

DME Polyester Film Capacitors are suitable for this job with capacitance around 0.47uF – 0,68uF will be satisfied.

Choose larger voltage rating than your power supply.

Search it at digikey.com -

<http://www.digikey.com/scripts/dksearch/dksus.dll?FV=ffec2aa9%2Cfff40002%2Cfff80010%2Ce34003&k=Polyester+Film+Capacitor&vendor=0&mnonly=0&newproducts=0&ptm=0&fid=0&quantity=0&PV13=46&PV13=47&PV13=49>

If you can't find it, you can use other Metalized Polyester Film Capacitor.

5 Technical specifications

Parameter *	Value	Unit
Basic Specification		
Number of relays	4	
Digital circuit power supply voltage	9 - 24	V
Standby current at 12V	80	mA
Maximum current drawn by digital circuitry at 9V	270	mA
Maximum current drawn by digital circuitry at 12V	200	mA
Maximum current drawn by digital circuitry at 24V	100	mA
Relay Specifications		
Nominal relay coil voltage	5	V
Nominal coil power consumption (per relay)	360	mW
Relay contact material	Ag alloy	
Contact rating	AC125V 15A AC250V 10A DC24V 15A	
Maximum switching voltage	AC 240V DC 110V	
Maximum switching current	20	A
Maximum switching power	2500VA	
Contact resistance (initial)	50	mΩ
Life expectancy (Electrical)	100,000 ops	
Life expectancy (Mechanical)	10,000,000 ops	
Nominal insulation resistance	100MΩ (DC500V)	
Maximum switching on response time	10	ms
Maximum switching off response time	5	ms

* All parameters considered nominal. KMTronic LTD reserves the right to modify products without notice.

6 Physical Dimensions

- Standard board

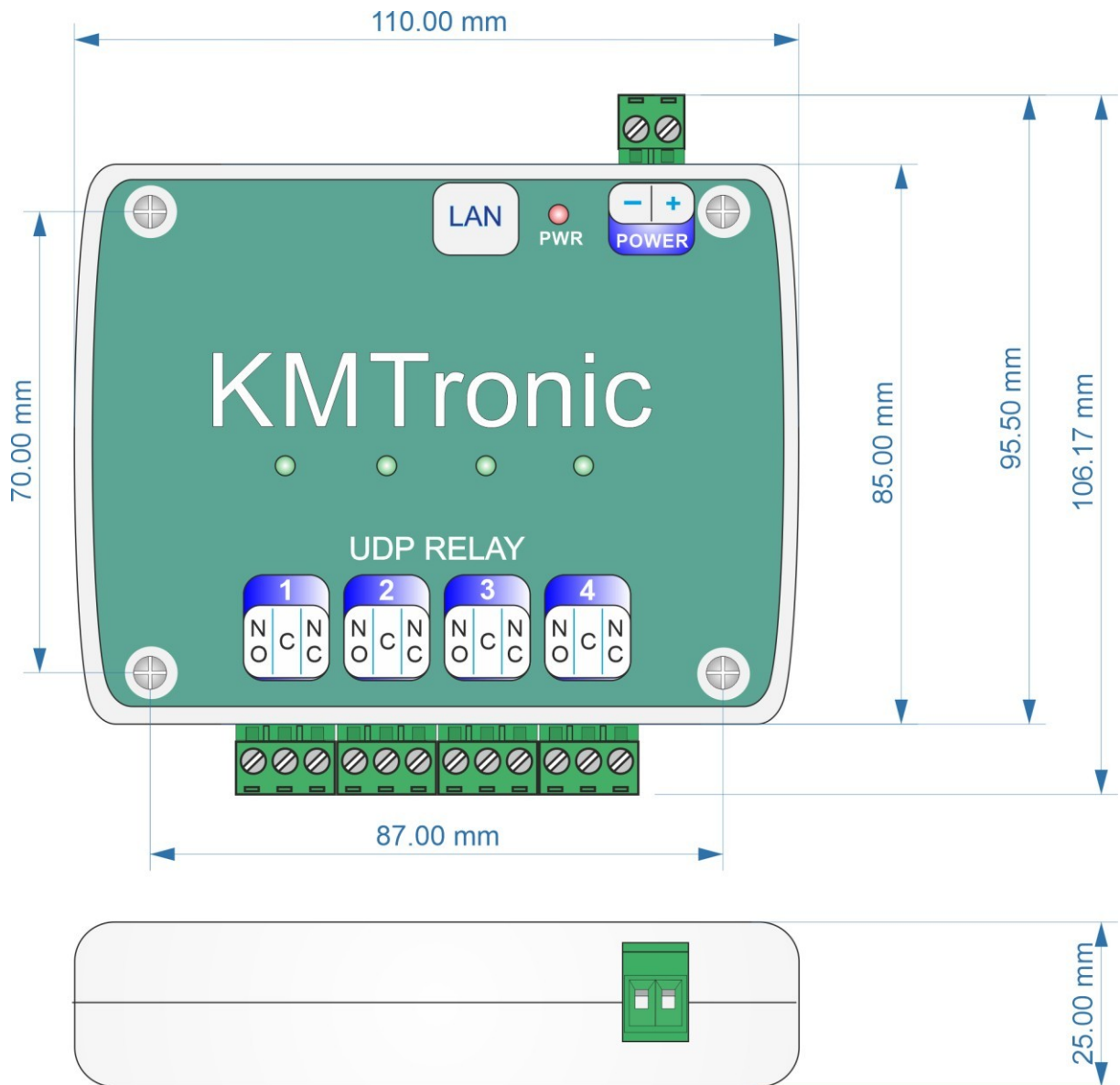

- DIN mounting

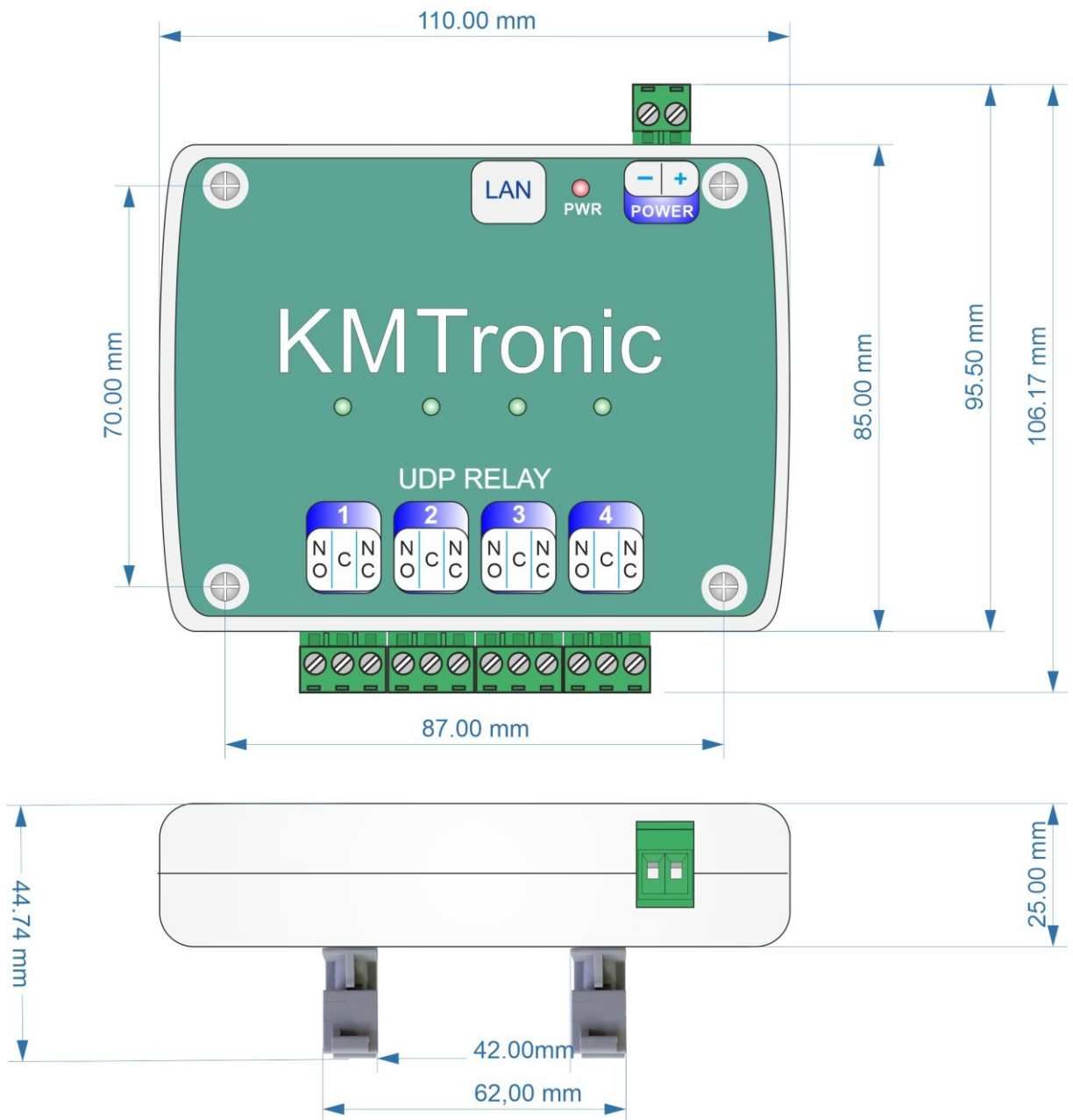

7. Other information

You can find test software and programs, as well as additional information at:

<http://www.kmtronic.com/>

Manufacture by:
KMTronic LTD
 Bulgaria