

KMTRONIC
LTD

Relay Controller Model U8CR User Guide



Contents

- I. CONNECTING AND OPERATION..... 1
 - 1. Security and Handling 1
 - 2. An Overview 1
 - 2.1 Specification 2
 - 2.2 Package Contents..... 2
 - 2.3 Operation Requirements..... 2
 - 3 How to use USB Eight Relay..... 3
 - 3.1 Connection Details..... 3
 - 3.2 Driver installation 4
 - 3.3 Run our test program..... 5
 - 3.4 List of command set..... 6
 - 4 Additional information 7
 - 4.1 Handle inductive loads..... 7
 - 5 Technical specifications..... 8
 - 6 Physical Dimensions 9
 - 7 Sample code & Demo Applications..... 9

I. CONNECTING AND OPERATION

1. Security and Handling

Safety Instructions:

This device may connect to the USB port of your computer and can be used to control external devices connected to its onboard relays. Incorrect wiring or shorts on the board can potentially cause damage to the controller itself, your computer's USB controller and/or your computer's motherboard if an external voltage make its way to the USB bus or the USB port is shorted. Extreme care must be taken when using this device to avoid any damage to your equipment. In particular, make sure you always disconnect the device from the USB port as well as any other power source when working on the device.

KMTronic, its shareholder, employees, suppliers, distributors and/or resellers are not liable for any damage or loss of data as a result of the use of this device, including special, incidental, or consequential damages resulting from the use of this device, or under any legal theory, including lost profits, downtime, goodwill, damage to or replacement of equipment or property, and any costs or recovering or reproducing any data stored in computers connected to this device.

Your use of this circuit indicates your acceptance of these terms

2. An Overview

KMTronic USB Eight Relay is a versatile product for controlling electrical and electronic devices remotely from a PC over USB link. Ease of use and wider operating system compatibility are the primary goals behind the product's design. Built in USB to serial conversion allows the module to be used without any USB specific knowledge. This simplicity allows use programs such as Docklight or other RS232 terminal programs. For power users, this module can be controlled by writing programs in various programming languages.

Some of possible uses of the module include

- Home Automation
- Lighting Control
- Garden Equipment Control
- Industrial Automation
- Test Fixtures
- DIY and Hobby

And these are some of the languages that can be used for programming

- C/C++/C#
- Visual Basic (VB6, VB2008,VB2010 express and other editions)
- Visual Basic for Applications (Microsoft Office VBA)
- Perl

- Python
- Java
- And many more...

2.1 Specification

- Number of Relays : 8
- Rated voltage: 12V DC
- Relay switching power: 15A/24VDC(125VAC)10A/250VAC
- Baud rate : 9600/8/N/1
- Communication Port : USB Serial Port
- Dimension: 149mm x 110mm x 25mm (connectors mounted)

2.2 Package Contents

The following is included in the USB Eight Relay package

- USB Eight Relay board

2.3 Operation Requirements

This product is compatible with the following operating systems

- Windows XP and later
- Linux
- Mac
- And any other operating system that supports FTDI devices.

3 How to use USB Eight Relay

3.1 Connection Details

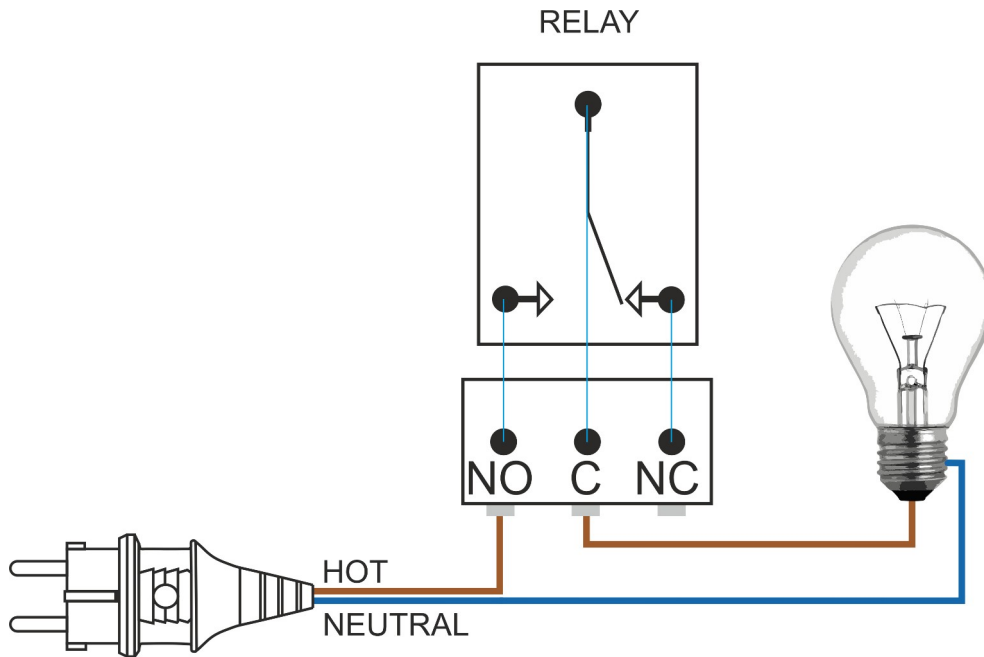

Above image shows basic connection diagram that can be used in most of the situations. The connection diagram is same for both AC and DC loads. Please make sure to use a freewheeling diode or snubber circuit if the load is inductive. More details about using inductive loads is available elsewhere in this document. Use a USB A to B cable for connection to PC. It is important to make sure that the wires used to connect loads are sufficiently rated to handle expected load current. Exercise caution while working with high voltages. Short circuits can cause damage to the module and the PC. The following sections identify individual connections in detail.

IMPORTANT NOTE



This circuit involves high voltage AC main power wiring when used to control high voltage AC devices. Please note that handling, testing and operating high voltage AC powered equipment can be dangerous and fatal when basic safety rules are not followed. ALWAYS disconnect the circuit from the AC line prior to performing any work on the circuit.

If you are inexperienced or not confident in working with high voltage AC powered circuits, we strongly recommend that you DO NOT attempt to use this circuit and seek help of a licensed electrician.

USB Interface

The on board full speed USB controller that helps a PC/Linux/Mac computer to communicate and control this module seamlessly. You will need to use a USB A to B cable for connection to the PC



Relay Contacts

All contacts on each relay are available externally on screw terminals for easy user access. The relays are rated for AC and DC supply voltages. Please see the electrical parameter table for more details. Each relay has three contacts(C, NO and NC). C is the common terminal and is used in both normally open and normally closed positions. The contacts NC and C will be connected when the relay is turned off and will be disconnected when relay is turned on. And vice versa, the contacts C and NO will be disconnected when relay is turned off and will be connected when the relay is turned on. Table below summarizes possible relay contact



Relay State	Connection between NC and C	Connection between NO and C
OFF	Close	Open
ON	Open	Close

DC Power Supply

This board need +12V DC power supply for function properly. The +12V supply for the relay coils is **not optional** and the relay will not switch without this supply. Any off the shelf 12V DC / 500mA or more power supply can be used for this purpose. Make sure to connect the power supply in correct polarity. Connect the positive terminal of the power supply to the + terminal on the module. Connect negative terminal of the power supply to - terminal of the module.



3.2 Driver installation

You can download the driver from here: [Driver Download](#)

Windows:

This product requires a driver to be installed for proper functioning when used with windows. The driver package can be downloaded from the product page.

To install the driver, unzip the contents of the downloaded driver package to a folder. Attach USB cable to the PC and when asked by Windows device installation wizard, point to the folder where driver files are present. When driver installation is complete, the module should appear in Windows Device Manager as a serial port (see the picture on the right). Note down the name of the serial port (COM1, COM2 etc..). This information is required to control the module from the PC.

Linux:

To use this product with Linux you don't need to install any drivers. They are included in most distributions like Ubuntu and others. When connected to a Linux machine, this product should appear as a serial port in the /dev directory. Usually the name of the device will be "ttyUSBx" or

similar. The name may be different depending on the Linux distribution you have.

Mac:

Similar to Linux, Mac operating system comes with the pre-installed drivers. When connected to a Mac computer, the device should appear as a serial port.

3.3 Run our test program

You can download the program from: [KMTronic USB Relay Test Software](http://sigma-shop.com/)

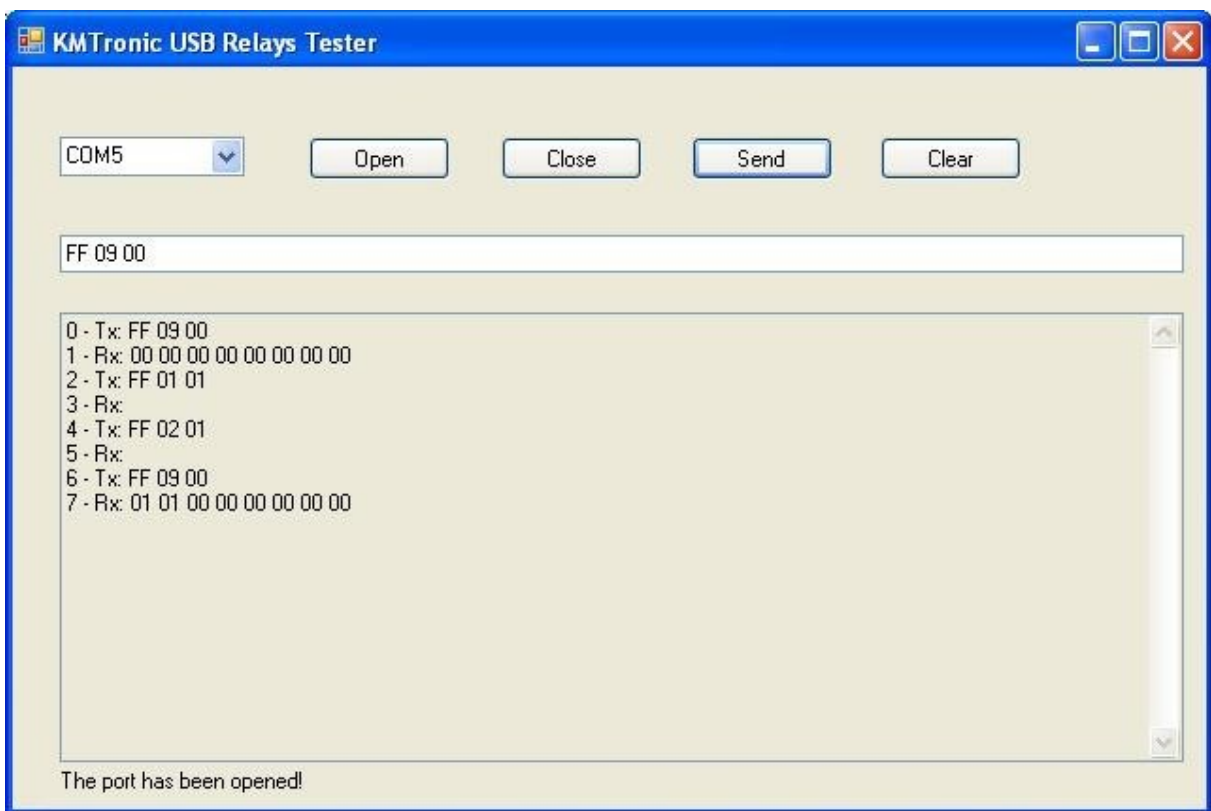

3.4 List of command set

No.	Command	Format	Description
1	FF 01 01	HEX	Turn ON relay 1
2	FF 02 01	HEX	Turn ON relay 2
3	FF 03 01	HEX	Turn ON relay 3
4	FF 04 01	HEX	Turn ON relay 4
5	FF 05 01	HEX	Turn ON relay 5
6	FF 06 01	HEX	Turn ON relay 6
7	FF 07 01	HEX	Turn ON relay 7
8	FF 08 01	HEX	Turn ON relay 8
9	FF 01 00	HEX	Turn OFF relay 1
10	FF 02 00	HEX	Turn OFF relay 2
11	FF 03 00	HEX	Turn OFF relay 3
12	FF 04 00	HEX	Turn OFF relay 4
13	FF 05 00	HEX	Turn OFF relay 5
14	FF 06 00	HEX	Turn OFF relay 6
15	FF 07 00	HEX	Turn OFF relay 7
16	FF 08 00	HEX	Turn OFF relay 8
17	FF 09 00	HEX	Status request command Reply from the board : xx xx xx xx xx xx xx xx where xx is : 01 – relay is ON 00 – relay is OFF for example: 01 00 00 00 00 00 00 00 (only first relay is on)
18	FF 0A xx	HEX	Set the status of the relays in HEX format where (xx) is the last byte corresponding for each relay. For example: FF 0A FF – All relay ON FF 0A 00 – All relay OFF FF 0A 10 – only (5) relay ON all others OFF and so on....

4 Additional information

4.1 Handle inductive loads

General-purpose relays are typically designed to drive resistive loads, not inductive loads.

This is why electromechanical life ratings are published for resistive loads and not inductive loads. Inductive loads can best be defined as anything with a magnetic coil, such as a motor, solenoid, or a transformer. The purpose of this capacitor is to absorb the high voltages generated by inductive loads. Unlike resistive loads, inductive loads love power, and they will do everything they can to hold on to it. The unpleasant result of this power hunger is inductive kickback, and it has a devastating effect on the contact life of most general-purpose relays. This is true of both ac and dc inductive loads, although the inductive kickback is far worse with dc loads due to the constant current characteristic of dc power. How bad is the kickback? A 24-Vdc solenoid with a current consumption as low as a quarter of an amp will create a negative inductive kickback of more than 300 V. Also the high voltage kickbacks can easily brake the USB communication and the only way to fix it to unplug and plug it again.

Adding a suppression capacitor could easily reduce the problems. It has to be installed as close as possible to the Relay Board.

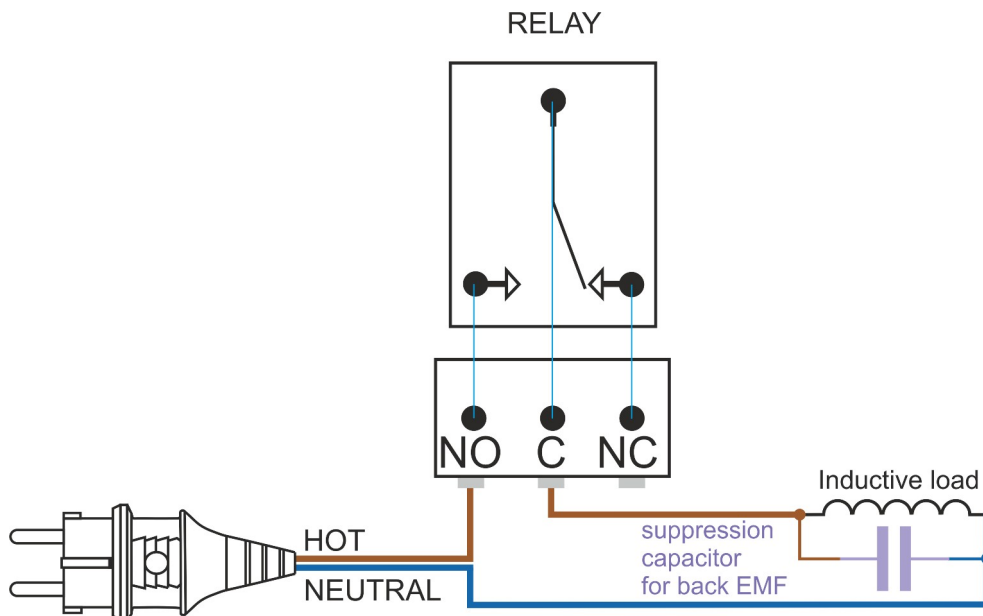

DME Polyester Film Capacitors are suitable for this job with capacitance around 0.47uF – 0,68uF will be satisfied.

Choose larger voltage rating than your power supply.

Search it at digikey.com -

<http://www.digikey.com/scripts/dksearch/dksus.dll?FV=ffec2aa9%2Cfff40002%2Cfff80010%2Ce34003&k=Polyester+Film+Capacitor&vendor=0&mnonly=0&newproducts=0&ptm=0&fid=0&quantity=0&PV13=46&PV13=47&PV13=49>

If you can't find it you can use other Metalized Polyester Film Capacitor.

5 Technical specifications

Parameter *	Value	Unit
Basic Specification		
Number of relays	8	
Digital circuit power supply voltage (USB or external)	12	V
Standby current USB ALL Relays OFF	13	mA
Standby current USB ALL Relays ON	25	mA
Standby current 12V rail	5	mA
Maximum current drawn by digital circuitry	300	mA
Relay Specifications		
Nominal relay coil voltage	12	V
Nominal coil power consumption (per relay)	360	mW
Relay contact material	Ag alloy	
Contact rating	AC125V 15A AC250V 10A DC24V 15A	
Maximum switching voltage	AC 240V DC 110V	
Maximum switching current	20	A
Maximum switching power	2500VA	
Contact resistance (initial)	50	mΩ
Life expectancy (Electrical)	100,000 ops	
Life expectancy (Mechanical)	10,000,000 ops	
Nominal insulation resistance	100MΩ (DC500V)	
Maximum switching on response time	10	ms
Maximum switching off response time	5	ms

* All parameters considered nominal. KMTronic LTD reserves the right to modify products without notice.

6 Physical Dimensions

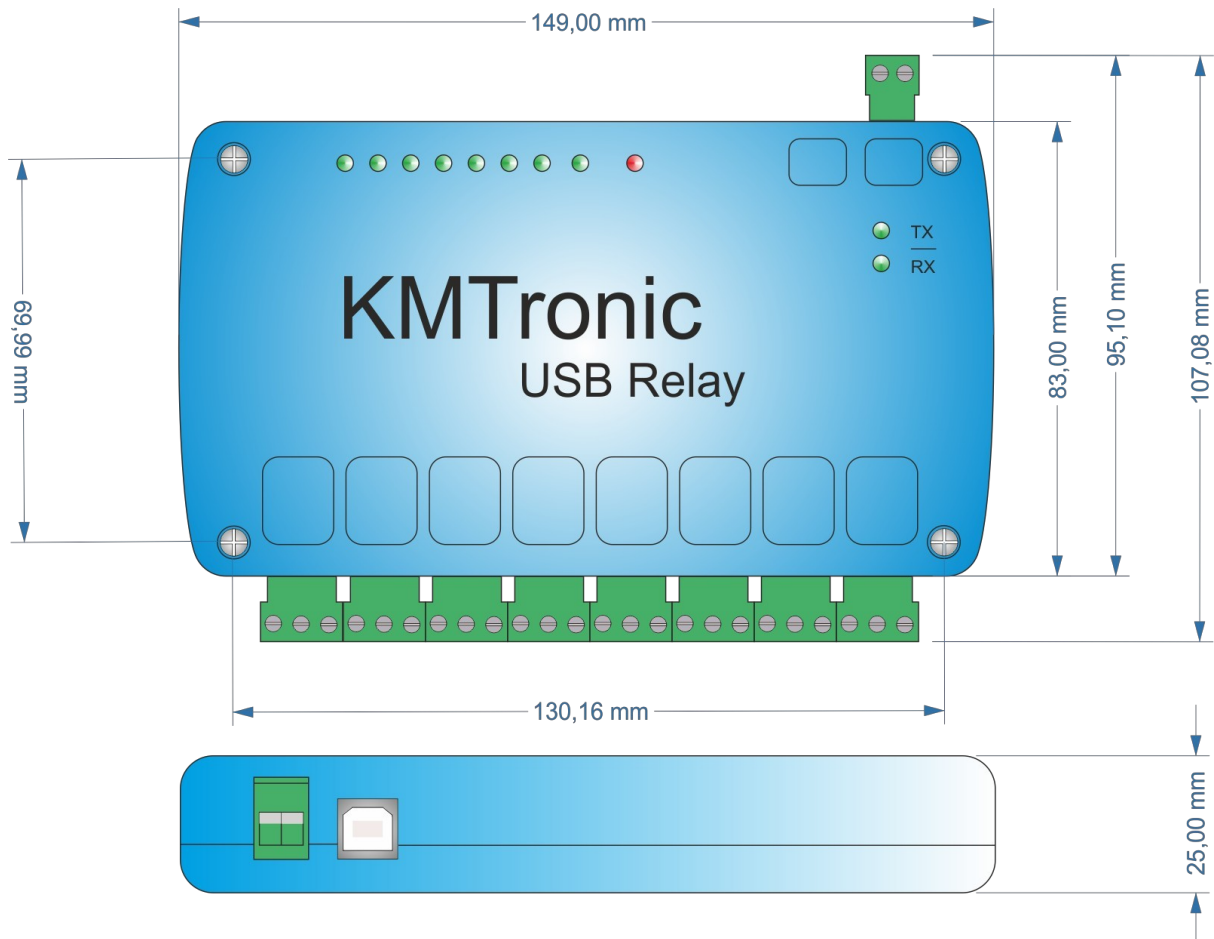

7 Sample code & Demo Applications

You can find sample code and a demo application, as well as additional information and downloads at:

<http://info.kmtronic.com/>

Manufacture By:
KMTronic LTD
Bulgaria