

KMTRONIC
LTD

Relay Controller Model R4S4RD User Guide



Contents

- I. CONNECTING AND OPERATION 1
 - 1. Security and Handling 1
 - 2. An Overview 1
 - 2.1 Specification 1
 - 2.2 Package Contents 2
 - 2.3 Operation Requirements 2
 - 3 How to use KMTronic RS485 Relay 2
 - 3.1 Connection Details 2
 - 3.2 List of command set 5
 - 4 Additional information 13
 - 4.1 Handle inductive loads 13
 - 5 Technical specifications 14
 - 6 Physical Dimensions 15
 - 7 Sample code & Demo Applications 15

I. CONNECTING AND OPERATION

1. Security and Handling

Safety Instructions:

This device may have used to control external devices connected to its onboard relays. Incorrect wiring or shorts on the board can potentially cause damage to the board itself, your device. Extreme care must be taken when using this device to avoid any damage to your equipment. In particular, make sure you always disconnect the power of external device before touch the board.

KMTronic, its shareholder, employees, suppliers, distributors and/or resellers are not liable for any damage or loss of data as a result of the use of this device, including special, incidental, or consequential damages resulting from the use of this device, or under any legal theory, including lost profits, downtime, goodwill, damage to or replacement of equipment or property, and any costs or recovering or reproducing any data stored in computers connected to this device.

Your use of this circuit indicates your acceptance of these terms

2. An Overview

KMTronic RS485 Relay is a versatile product for controlling electrical and electronic devices remotely from a PC over RS485 bus. Ease of use and wider operating system compatibility are the primary goals behind the product's design.

Some of possible uses of the module include

- Home Automation
- Lighting Control
- Garden Equipment Control
- Industrial Automation
- Test Fixtures
- DIY and Hobby

2.1 Specification

- Number of Relays: 4
- Rated voltage: 9 - 24V DC
- Relay switching power: 15A/24VDC(125VAC) 10A/250VAC
- Baud rate: 9600/8/N/1
- Communication Port: RS485
- Dimension : 109mm x 108mm x 25mm (connectors mounted)

2.2 Package Contents

The following is included in the KMTronic RS485 Relay package

- KMTronic RS485 Relay

2.3 Operation Requirements

- DC power supply from 9 to 24V
- Medium size screw driver

3 How to use KMTronic RS485 Relay

3.1 Connection Details

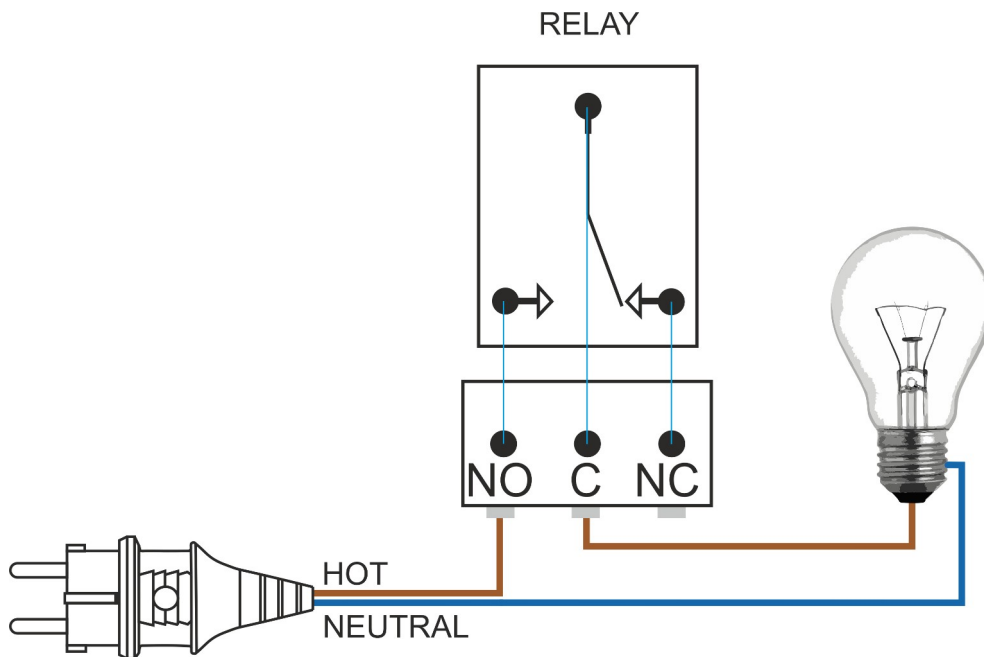

Above image shows basic connection diagram that can be used in most of the situations. The connection diagram is same for both AC and DC loads. Please make sure to use a freewheeling diode or snubber circuit if the load is inductive. More details about using inductive loads is available elsewhere in this document. It is important to make sure that the wires used to connect loads are sufficiently rated to handle expected load current. Exercise caution while working with high voltages. Short circuits can cause damage to the module and the PC. The following sections identify individual connections in detail.

IMPORTANT NOTE



This circuit involves high voltage AC main power wiring when used to control high voltage AC devices. Please note that handling, testing and operating high voltage AC powered equipment can be dangerous and fatal when basic safety rules are not followed. **ALWAYS** disconnect the circuit from the AC line prior to performing any work on the circuit.

If you are inexperienced or not confident in working with high voltage AC powered circuits, we strongly recommend that you **DO NOT** attempt to use this circuit and seek help of a licensed electrician.

Relay Contacts

All contacts on each relay are available externally on screw terminals for easy user access. The relays are rated for AC and DC supply voltages. Please see the electrical parameter table for more details. Each relay has three contacts (C, NO and NC). C is the common terminal and is used in both normally open and normally closed positions. The contacts NC and C will be connected when the relay is turned off and will be disconnected when relay is turned on. And vice versa, the contacts C and NO will be disconnected when relay is turned off and will be connected when the relay is turned on. Table below summarizes possible relay contact



Relay State	Connection between NC and C	Connection between NO and C
OFF	Close	Open
ON	Open	Close

DC Power Supply

This board needs from 9V – 24V DC power supply for function properly. The board will need at least 200mA for 9V, 150mA for 12V and 70mA for 24V. Make sure to connect the power supply in correct polarity. Connect the positive terminal of the power supply to the + terminal on the module. Connect negative terminal of the power supply to - terminal of the module.

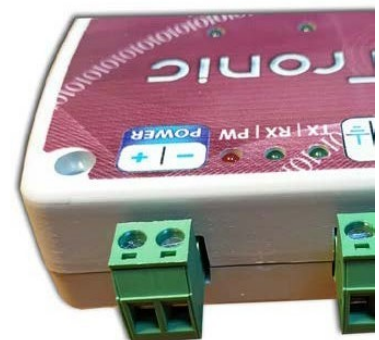

RS485 A and B lines

Connect A pin of our board to A line of your RS485 adapter and B pin of our board to B pin of your RS485 adapter. You can leave GND connection float.

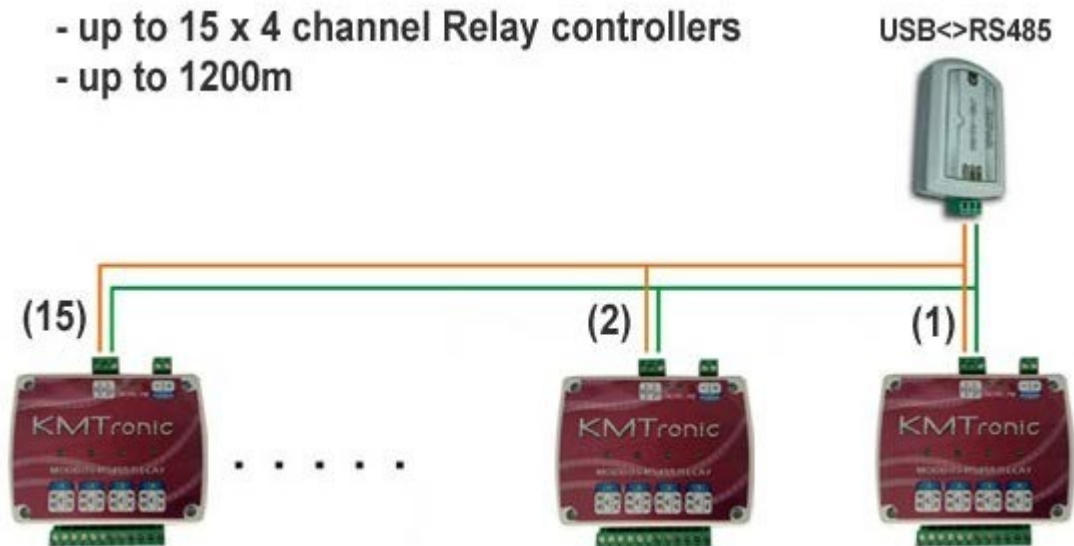

DIP Switch ID Select

You can connect up to 15 board to single RS485 bus by simple selecting different IDs from integrated switch.



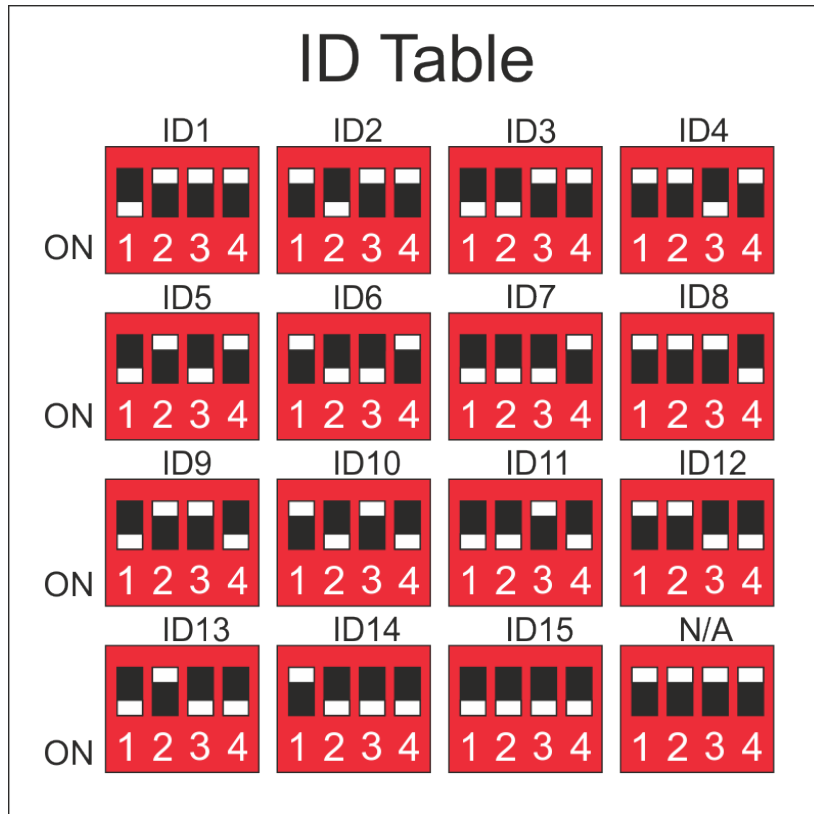

3.2 List of command set

		Command		Format	Description
No		ON	OFF		
ID1	1	FF 01 01	FF 01 00	HEX	Turn ON and OFF Relay1
	2	FF 02 01	FF 02 00	HEX	Turn ON and OFF Relay2
	3	FF 03 01	FF 03 00	HEX	Turn ON and OFF Relay3
	4	FF 04 01	FF 04 00	HEX	Turn ON and OFF Relay4
	5	FF A1 00		HEX	Status request command Reply from the board: FF A1 xx xx xx xx FF FF FF FF where xx is: 01 – relay is ON 00 – relay is OFF for example: FF A1 01 00 00 00 FF FF FF FF (only first relay is on)

Command			Format	Description	
No					
	ON	OFF			
ID2	1	FF 09 01	FF 09 00	HEX	Turn ON and OFF Relay1
	2	FF 0A 01	FF 0A 00	HEX	Turn ON and OFF Relay2
	3	FF 0B 01	FF 0B 00	HEX	Turn ON and OFF Relay3
	4	FF 0C 01	FF 0C 00	HEX	Turn ON and OFF Relay4
	5			HEX	Status request command Reply from the board: FF A2 xx xx xx xx FF FF FF FF where xx is: 01 – relay is ON 00 – relay is OFF for example: FF A2 01 00 00 00 FF FF FF FF (only first relay is on)
	ON	OFF			
ID3	1	FF 11 01	FF 11 00	HEX	Turn ON and OFF Relay1
	2	FF 12 01	FF 12 00	HEX	Turn ON and OFF Relay2
	3	FF 13 01	FF 13 00	HEX	Turn ON and OFF Relay3
	4	FF 14 01	FF 14 00	HEX	Turn ON and OFF Relay4
	9			HEX	Status request command Reply from the board: FF A3 xx xx xx xx FF FF FF FF where xx is: 01 – relay is ON 00 – relay is OFF for example: FF A3 01 00 00 00 FF FF FF FF (only first relay is on)

Command			Format	Description	
No					
	ON	OFF			
ID4	1	FF 19 01	FF 19 00	HEX	Turn ON and OFF Relay1
	2	FF 1A 01	FF 1A 00	HEX	Turn ON and OFF Relay2
	3	FF 1B 01	FF 1B 00	HEX	Turn ON and OFF Relay3
	4	FF 1C 01	FF 1C 00	HEX	Turn ON and OFF Relay4
	5			HEX	Status request command Reply from the board: FF A4 xx xx xx xx FF FF FF FF where xx is: 01 – relay is ON 00 – relay is OFF for example: FF A4 01 00 00 00 FF FF FF FF (only first relay is on)
	ON	OFF			
ID5	1	FF 21 01	FF 21 00	HEX	Turn ON and OFF Relay1
	2	FF 22 01	FF 22 00	HEX	Turn ON and OFF Relay2
	3	FF 23 01	FF 23 00	HEX	Turn ON and OFF Relay3
	4	FF 24 01	FF 24 00	HEX	Turn ON and OFF Relay4
	5			HEX	Status request command Reply from the board: FF A5 xx xx xx xx FF FF FF FF where xx is: 01 – relay is ON 00 – relay is OFF for example: FF A5 01 00 00 00 FF FF FF FF (only first relay is on)

Command			Format	Description	
No					
	ON	OFF			
ID6	1	FF 29 01	FF 29 00	HEX	Turn ON and OFF Relay1
	2	FF 2A 01	FF 2A 00	HEX	Turn ON and OFF Relay2
	3	FF 2B 01	FF 2B 00	HEX	Turn ON and OFF Relay3
	4	FF 2C 01	FF 2C 00	HEX	Turn ON and OFF Relay4
	5			HEX	Status request command Reply from the board: FF A6 xx xx xx xx FF FF FF FF where xx is: 01 – relay is ON 00 – relay is OFF for example: FF A6 01 00 00 00 FF FF FF FF (only first relay is on)
	ON	OFF			
ID7	1	FF 31 01	FF 31 00	HEX	Turn ON and OFF Relay1
	2	FF 32 01	FF 32 00	HEX	Turn ON and OFF Relay2
	3	FF 33 01	FF 33 00	HEX	Turn ON and OFF Relay3
	4	FF 34 01	FF 34 00	HEX	Turn ON and OFF Relay4
	5			HEX	Status request command Reply from the board: FF A7 xx xx xx xx FF FF FF FF where xx is: 01 – relay is ON 00 – relay is OFF for example: FF A7 01 00 00 00 FF FF FF FF (only first relay is on)

		Command		Format	Description
No					
		ON	OFF		
ID8	1	FF 39 01	FF 39 00	HEX	Turn ON and OFF Relay1
	2	FF 3A 01	FF 3A 00	HEX	Turn ON and OFF Relay2
	3	FF 3B 01	FF 3B 00	HEX	Turn ON and OFF Relay3
	4	FF 3C 01	FF 3C 00	HEX	Turn ON and OFF Relay4
	5			HEX	Status request command Reply from the board: FF A8 xx xx xx xx FF FF FF FF where xx is: 01 – relay is ON 00 – relay is OFF for example: FF A8 01 00 00 00 FF FF FF FF (only first relay is on)
		ON	OFF		
ID9	1	FF 41 01	FF 41 00	HEX	Turn ON and OFF Relay1
	2	FF 42 01	FF 42 00	HEX	Turn ON and OFF Relay2
	3	FF 43 01	FF 43 00	HEX	Turn ON and OFF Relay3
	4	FF 44 01	FF 44 00	HEX	Turn ON and OFF Relay4
	5			HEX	Status request command Reply from the board: FF A9 xx xx xx xx FF FF FF FF where xx is: 01 – relay is ON 00 – relay is OFF for example: FF A9 01 00 00 00 FF FF FF FF (only first relay is on)

		Command		Format	Description
No					
		ON	OFF		
ID10	1	FF 49 01	FF 49 00	HEX	Turn ON and OFF Relay1
	2	FF 4A 01	FF 4A 00	HEX	Turn ON and OFF Relay2
	3	FF 4B 01	FF 4B 00	HEX	Turn ON and OFF Relay3
	4	FF 4C 01	FF 4C 00	HEX	Turn ON and OFF Relay4
	5			HEX	Status request command Reply from the board: FF AA xx xx xx xx FF FF FF FF where xx is: 01 – relay is ON 00 – relay is OFF for example: FF AA 01 00 00 00 FF FF FF FF (only first relay is on)
		ON	OFF		
ID11	1	FF 51 01	FF 51 00	HEX	Turn ON and OFF Relay1
	2	FF 52 01	FF 52 00	HEX	Turn ON and OFF Relay2
	3	FF 53 01	FF 53 00	HEX	Turn ON and OFF Relay3
	4	FF 54 01	FF 54 00	HEX	Turn ON and OFF Relay4
	5			HEX	Status request command Reply from the board: FF AB xx xx xx xx FF FF FF FF where xx is: 01 – relay is ON 00 – relay is OFF for example: FF AB 01 00 00 00 FF FF FF FF (only first relay is on)

		Command		Format	Description
No					
		ON	OFF		
ID12	1	FF 59 01	FF 59 00	HEX	Turn ON and OFF Relay1
	2	FF 5A 01	FF 5A 00	HEX	Turn ON and OFF Relay2
	3	FF 5B 01	FF 5B 00	HEX	Turn ON and OFF Relay3
	4	FF 5C 01	FF 5C 00	HEX	Turn ON and OFF Relay4
	5			HEX	Status request command Reply from the board: FF AC xx xx xx xx FF FF FF FF where xx is: 01 – relay is ON 00 – relay is OFF for example: FF AC 01 00 00 00 FF FF FF FF (only first relay is on)
		ON	OFF		
ID13	1	FF 61 01	FF 61 00	HEX	Turn ON and OFF Relay1
	2	FF 62 01	FF 62 00	HEX	Turn ON and OFF Relay2
	3	FF 63 01	FF 63 00	HEX	Turn ON and OFF Relay3
	4	FF 64 01	FF 64 00	HEX	Turn ON and OFF Relay4
	5			HEX	Status request command Reply from the board: FF AD xx xx xx xx FF FF FF FF where xx is: 01 – relay is ON 00 – relay is OFF for example: FF AD 01 00 00 00 FF FF FF FF (only first relay is on)

		Command		Format	Description
No					
		ON	OFF		
ID14	1	FF 69 01	FF 69 00	HEX	Turn ON and OFF Relay1
	2	FF 6A 01	FF 6A 00	HEX	Turn ON and OFF Relay2
	3	FF 6B 01	FF 6B 00	HEX	Turn ON and OFF Relay3
	4	FF 6C 01	FF 6C 00	HEX	Turn ON and OFF Relay4
	5			HEX	Status request command Reply from the board: FF AE xx xx xx xx FF FF FF FF where xx is: 01 – relay is ON 00 – relay is OFF for example: FF AE 01 00 00 00 FF FF FF FF (only first relay is on)
		ON	OFF		
ID15	1	FF 71 01	FF 71 00	HEX	Turn ON and OFF Relay1
	2	FF 72 01	FF 72 00	HEX	Turn ON and OFF Relay2
	3	FF 73 01	FF 73 00	HEX	Turn ON and OFF Relay3
	4	FF 74 01	FF 74 00	HEX	Turn ON and OFF Relay4
	5			HEX	Status request command Reply from the board: FF AF xx xx xx xx FF FF FF FF where xx is: 01 – relay is ON 00 – relay is OFF for example: FF AF 01 00 00 00 FF FF FF FF (only first relay is on)

4 Additional information

4.1 Handle inductive loads

General-purpose relays are typically designed to drive resistive loads, not inductive loads.

This is why electromechanical life ratings are published for resistive loads and not inductive loads. Inductive loads can best be defined as anything with a magnetic coil, such as a motor, solenoid, or a transformer. The purpose of this capacitor is to absorb the high voltages generated by inductive loads. Unlike resistive loads, inductive loads love power, and they will do everything they can to hold on to it. The unpleasant result of this power hunger is inductive kickback, and it has a devastating effect on the contact life of most general-purpose relays. This is true of both ac and dc inductive loads, although the inductive kickback is far worse with dc loads due to the constant current characteristic of dc power. How bad is the kickback? A 24-Vdc solenoid with a current consumption as low as a quarter of an amp will create a negative inductive kickback of more than 300 V. Also the high voltage kickbacks can easily brake the USB communication and the only way to fix it to unplug and plug it again.

Adding a suppression capacitor could easily reduce the problems. It has to be installed as close as possible to the Relay Board.

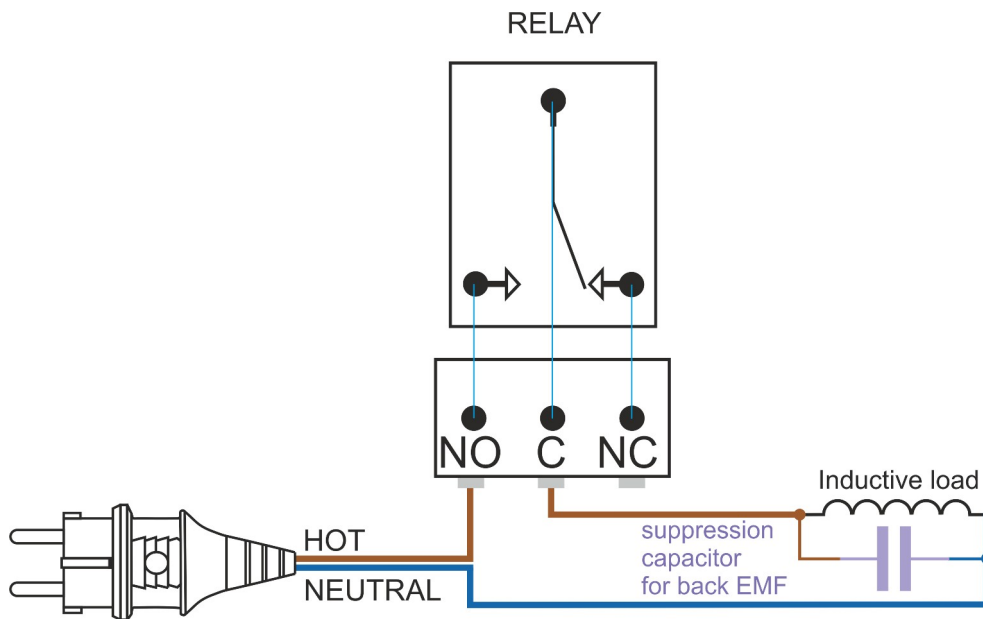

DME Polyester Film Capacitors are suitable for this job with capacitance around 0.47 μ F – 0,68 μ F will be satisfied.

Choose larger voltage rating than your power supply.

Search it at digikey.com -

<http://www.digikey.com/scripts/dksearch/dksus.dll?FV=ffec2aa9%2Cfff40002%2Cfff80010%2Ce340003&k=Polyester+Film+Capacitor&vendor=0&mnonly=0&newproducts=0&ptm=0&fid=0&quantity=0&PV13=46&PV13=47&PV13=49>

If you can't find it, you can use other Metalized Polyester Film Capacitor.

5 Technical specifications

Parameter *	Value	Unit
Basic Specification		
Number of relays	4	
Digital circuit power supply voltage (USB or external)	9 - 24	V
Standby current at 12V	20	mA
Maximum current drawn by digital circuitry at 9V	180	mA
Maximum current drawn by digital circuitry at 12V	140	mA
Maximum current drawn by digital circuitry at 24V	70	mA
Relay Specifications		
Nominal relay coil voltage	5	V
Nominal coil power consumption (per relay)	360	mW
Relay contact material	Ag alloy	
Contact rating	AC125V 15A AC250V 10A DC24V 15A	
Maximum switching voltage	AC 240V DC 110V	
Maximum switching current	20	A
Maximum switching power	2500VA	
Contact resistance (initial)	50	mΩ
Life expectancy (Electrical)	100,000 ops	
Life expectancy (Mechanical)	10,000,000 ops	
Nominal insulation resistance	100MΩ (DC500V)	
Maximum switching on response time	10	ms
Maximum switching off response time	5	ms

* All parameters considered nominal. KMTronic LTD reserves the right to modify products without notice.

6 Physical Dimensions

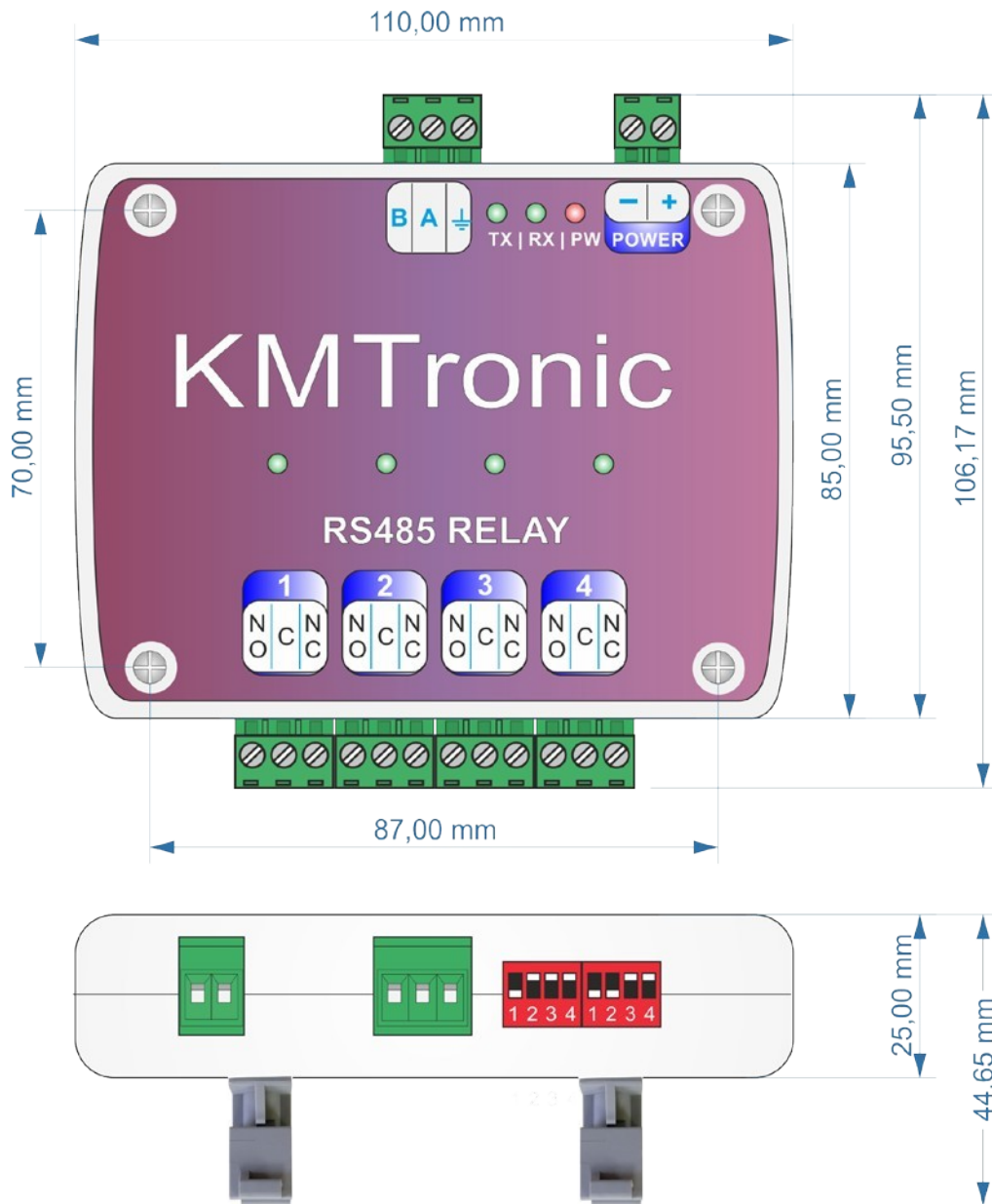

7 Sample code & Demo Applications

You can find sample code and a demo application, as well as additional information and downloads at:

<http://www.kmtronic.com/>

Manufacture by:
KMTronic LTD
Bulgaria

